

DB1000 SERIES DIGITAL INDICATING CONTROLLER



The DB1000 series is a 96×96mm digital indicating controller with the indicating accuracy of $\pm 0.1\%$ and the control cycle of approximately 0.1 seconds. Various functions including universal input and multiple setting values (8 types) are provided as standard.

■ FEATURES

● Large easy-to-view 5-digit display

Process value (PV) and set value (SV) are displayed by large easy-to-view 5-digit display indicators. The resolution of 0.1°C is enabled for more than 1000°C .

● Highly-functional operation screen and settings screen

The controller inherits the operation screen and the settings screen adopting the LCD (liquid-crystal-display) which has been familiarized for long time. Furthermore, the screens have become high-definition and highly sophisticated.

● Outstanding controllability

Two types of PID algorithms, the position-type PID algorithm and the speed-type PID algorithm, have been installed. You can select the optimum PID algorithm for an object controlled.

● Operability inheriting previous models

The controller inherits the settings screen which has been familiarized for long time. You can set up it with operation which is not different from previous models. The performance of touching-keys has been improved and the outstanding operability has been realized.

● High-precision remote signal input and transmission signal output

The high-precision (0.1% of full scale) analog remote signal input and the analog transmission signal output can be added.

● 24V power supply voltage type available

The power supply voltage 24V (AC/DC) type, which is advantageous in respect of safe, is available.



● Motor feedback value indication enabled in ON-OFF servo output type



[Operation screen of the ON-OFF servo output type]

Simultaneous indications of ON/OFF status of output, control output value (MV) and motor feedback value have been realized.

● Universal input

Various measurement ranges of DC voltage (up to maximum 10V) inputs, DC current input, thermocouple inputs and resistance thermometer inputs have been built-in.

● 2 colors of casing available

You can select the color of casing from 2 colors of gray with OA equipment feeling and black with high-class feeling.

● Conforming to international safety standards and European directives (CE)

The controller is in conformity with European directives (CE), and is UL and c-UL approved.

● Conforming to RoHS

The controller is an environmental consideration product which does not contain directed hazardous substances such as lead, etc.

■ NAMES OF VARIOUS PARTS



Display

Function keys

1. Operation status (RUN) indication
Lights in operation.
2. Slope (SLOPE) indication
Lights in slope operation of SV.
3. Alarm-standby (WAIT) indication
Lights in alarm-standby status or when alarm is cancelled.
4. Remote (REM) indication
5. Executing set value number (NO.) indication
6. Error (ERR) indication
Lights when sampling of input is abnormal.
7. Auto-tuning operation (AT) indication
Lights in auto-tuning operation.
8. Manual operation (MAN1/MAN2) indication
Lights when the output No.1 or No. 2 is in manual output operation.
15. Process value (PV) indication
16. Set value (SV) indication
17. Alarm activation (AL1 to 4) indication
18. LCD display

9. It is used for switching between the operation screen and the mode screen of Mode 0, or for switching from the settings screen to the mode screen.
10. It is used to switch the operation screen or to switch the settings screen.
11. It is used for switching between the automatic output operation and the manual output operation.
12. It is used for moving the cursor and for selecting a parameter.
13. It is used for changing a setting value (or selecting a parameter) in descending or ascending order.
14. It is used for registering the settings.
19. Engineering port

■ INPUT SPECIFICATIONS

Input type:	Thermocouple B, R, S, K, E, J, T, N, WRe5-WRe26, W-WRe26, NiMo-Ni, CR-AuFe, PR5-20, PtRh40-PtRh20, Platinel II, U, L DC voltage ±10mV, ±20mV, ±50mV, ±100mV, ±5V, ±10V DC current 0 to 20mA Resistance thermometer Pt100, JPt100, Old Pt100, JPt50, Pt-Co
Measuring range:	Thermocouple 28 ranges, DC voltage 6 ranges, DC current 1 range, Resistance thermometer 14 ranges * For details, refer to [Measuring ranges].
Accuracy rating:	±0.1% of measuring range ± 1 digit *For details, refer to [Detailed specifications of accuracy ratings].
Reference junction compensation accuracy:	K, E, J, T, N, Platinel II --- ±0.5°C or a value equivalent to ±20µV, whichever is greater (at ambient temperature of 23°C ± 10°C) Others --- ±1.0°C or a value equivalent to ±40µV, whichever is greater
Resolution:	Approx. 1/30000
Sampling rate:	Approx. 0.1 seconds
Burnout:	Upscale burnout is only enabled in thermocouple, DC voltage (±50mV or less) and resistance thermometer (3-wire type). For the burnout, the output value of Output No. 1 can be set arbitrarily, the output value of Output No. 2 is fixed at 0% and the high limit alarm is set to ON (for the upscale burnout). * The burnout is disabled in DC voltage (±100mV or more), DC current and resistance thermometer (4-wire type).
Input impedance:	Thermocouple 1MΩ or more DC voltage 1MΩ or more DC current Approx. 250Ω
Allowable signal source resistance:	Thermocouple 100Ω or less DC voltage (mV) 100Ω or less DC voltage (V) 300Ω or less
Allowable wire resistance (resistance thermometer):	5Ω or less (same resistance for all wires)
Rated current (resistance thermometer):	Approx. 1mA
Maximum allowable input:	Thermocouple ±20V, DC voltage ±20V DC current ±30mA, ±7.5V Resistance thermometer 500Ω, ±5V
Maximum common mode voltage:	30VAC
Common mode rejection ratio:	130dB or more (50/60Hz)
Normal mode rejection ratio:	50dB or more (50/60Hz)

■ DISPLAY SPECIFICATIONS

Display element:	Upper display LED Lower display LCD (with back light) 108 x 24 dots
Display content:	Upper display PV 5-digit, SV 5-digit, status indications, etc. Lower display MV, output status, setting screens, etc.

■ CONTROL SPECIFICATIONS

Control cycle:	Approx. 0.1 seconds
Output type:	ON-OFF pulse type, ON-OFF servo type, Current output type, SSR drive pulse type, Voltage output type
ON-OFF pulse type:	Output signal ON-OFF pulse conductive signal Contact capacity Resistive load 100 to 240VAC 30VDC 5A or less Inductive load 100 to 240VAC 30VDC 2.5A or less Smallest load 5VDC 10mA or more Contact protection Small CR element built-in ON-OFF pulse cycle 1 to 180 seconds
ON-OFF servo type:	Output signal ON-OFF servo conductive signal Contact capacity of standard load Resistive load 100 to 240VAC 30VDC 5A or less Inductive load 100 to 240VAC 30VDC 2.5A or less Smallest load 5VDC 10mA or more Contact capacity of very light load Resistive load 100 to 240VAC 30VDC 20mA or less Inductive load 100 to 240VAC 30VDC 20mA or less Smallest load 5VDC 1mA or more Feedback resistance 100Ω to 2kΩ Contact protection Small CR element built-in
Current output type:	Output signal 4 to 20mA Load resistance 750Ω or less
SSR drive pulse type:	Output signal ON-OFF pulse voltage signal Output voltage ON voltage 12VDC ± 20% OFF voltage 0.8VDC or less Load current 20mA or less Pulse cycle 1 to 180 seconds
Voltage output type:	Output signal 0 to 10V Output impedance Approx. 10Ω

■ SETTING SPECIFICATIONS

SV relations:	SV 8 types (maximum 5 digits setting) SV rate-of-change
Control relations:	PID 8 types P 0 to 999.9% I ∞, 1 to 9999 seconds D 0 to 9999 seconds A.R.W. (Anti reset windup) High limit --- 0 to 100.0% Low limit --- -100 to 0.0%
Output relations:	Output deadband Output preset Output limiter 8 types Rate-of-change limiter for output 8 types
Alarm relations:	Alarm value 4 points 8 types, alarm types, alarm deadband

■ ALARM SPECIFICATIONS

Number of alarm points:	4 points
Alarm types:	Absolute value alarm, deviation alarm
Output signal:	Relay output signal (a contact) 1 common terminal for AL1 and AL2, 1 common terminal for AL3 and AL4 Contact capacity Resistive load 100 to 240VAC 30VDC 3A or less Inductive load 100 to 240VAC 30VDC 1.5A or less Smallest load 5VDC 10mA or more

■ GENERAL SPECIFICATIONS

Rated power voltage: General power supply specifications 100 to 240VAC
24V power supply specifications 24VAC/24VDC

Rated power supply frequency:
General power supply specifications 50/60Hz
24V power supply specification 50/60Hz (24VAC)

Maximum power consumption:

General power supply specifications	
Without options	100VAC 10VA 240VAC 15VA
With options	100VAC 15VA 240VAC 20VA
24V power supply specifications	
Without options	24VAC 10VA 24VDC 5W
With options	24VAC 15VA 24VDC 10W

Working temperature range:
-10 to 50°C

Working humidity range:
10 to 90%RH

Power failure countermeasures:
Settings stored in EEPROM
(Rewrite count: One million times or less)

Terminal screws: M3.5

Insulation resistance: Between primary terminals and secondary terminals
20MΩ or more (500VDC)

Between primary terminals and ground terminal
20MΩ or more (500VDC)

Between secondary terminals and ground terminal
20MΩ or more (500VDC)

*Primary terminal: Terminals for power supply (100 to 240VAC), control output and alarm output

Withstand voltage: Between primary terminals and secondary terminals
1500VAC (for 1 minute)

Between primary terminals and ground terminal
1500VAC (for 1 minute)

Between secondary terminals and ground terminal
500VAC (for 1 minute)

*Primary terminal: Terminals for power supply (100 to 240VAC), control output and alarm output

Casing: Fire-retardant polycarbonate

Color: Gray or black

Mounting: Panel mounting

External dimensions: 96 (H) x 96 (W) x 127 (D)

*The depth from the front panel is 120mm.

Weight: Without options Approx. 450g

With options Approx. 580g

■ SAFETY STANDARD

CE : EN61326: 1997 +A1+A2+A3
EN61010-1: 2001 (Overvoltage category II, pollution degree 2)

* Under the test conditions of EMC directives, there may be variation of indication value or output value which is equivalent to maximum $\pm 10\%$ or maximum 2mV, whichever is greater.

UL: UL61010-1 2nd edition

c-UL: CAN/CSA C22.2 No.61010-1-04

■ REFERENCE OPERATING CONDITIONS

Ambient temperature: 23°C \pm 2°C

Ambient humidity: 55%RH \pm 5% (no dew condensation)

Power voltage: General power supply specifications
100VAC \pm 1%
24V power supply specifications
24VDC \pm 1%

Power supply frequency:
General power supply specifications
50/60Hz \pm 0.5%
24V power supply specifications
DC

Mounting angle: Forward or backward $\pm 3^\circ$, lateral $\pm 3^\circ$

Installation height: Altitude 2000m or below

Vibration: 0m/s²

Shock: 0m/s²

Mounting condition: Single-unit panel mounting (Space above, below, right and left of the unit is needed.)

Wind: None

External noise: None

Warm up time: 30 min. or longer

■ NORMAL OPERATING CONDITIONS

Ambient temperature: -10°C to 50°C (-10°C to 40°C for closed mounting)

Ambient humidity: 10 to 90%RH (no dew condensation)

Power voltage: General power supply specifications 90 to 264VAC
24V Power supply specifications 21.6 to 26.4VDC/AC

Power supply frequency:
General power supply specifications 50/60Hz \pm 2%
24V Power supply specifications DC, 50/60Hz \pm 2%

Mounting angle: Forward or backward $\pm 10^\circ$, lateral $\pm 10^\circ$

Installation height: Altitude 2000m or below

Vibration: 2m/s²

Shock: 0m/s²

Mounting condition: Single-unit panel mounting (Space above and below of the unit is needed.)

External noise: None

Rate of ambient temperature change:
10°C/hour or less

■ TRANSPORT CONDITIONS

Ambient temperature: -20°C to 60°C

Ambient humidity: 5 to 90%RH (no dew condensation)

Vibration: 4.9m/s² (10 to 60Hz)

Shock: 392m/s²

Under the condition that the unit is packed for shipment by the factory

■ STORAGE CONDITIONS

Ambient temperature: -20°C to 60°C

For long term storage, the temperature should be 10°C to 30°C.

Ambient humidity: 5 to 90%RH (no dew condensation)

Vibration: 0m/s²

Shock: 0m/s²

Under the condition that the unit is packed for shipment by the factory

■ OPTIONS

● Transmission signal output

Output a signal corresponding to set value (SV), process value (PV), manipulated value (MV), etc.

Number of output: 1 point
 Output signal: 4 - 20mA (Load resistance 400Ω or less)
 0 - 1V
 (Output resistance Approx.10Ω, Load resistance 50kΩ or more)
 0 - 10V
 (Output resistance Approx.10Ω, Load resistance 50kΩ or more)

Output accuracy: ±0.1% of full scale

● Remote signal input

By using external contacts, switching of remote mode and local mode is enabled. With the remote mode, the setting of SV is enabled by remote signal.

Number of inputs: 1 point
 Input signal: 4 - 20mA (Input impedance Approx.50Ω)
 0 - 1V (Input impedance Approx. 500kΩ)
 0 - 10V (Input impedance Approx.100kΩ)

Input accuracy: ±0.1% ± 1digit

Remote signal input: R/L (Remote/Local)

● Communications interface

With RS232C, RS422A or RS485, the setting and measured values of the controller can be transmitted to a master CPU and various parameters can be set by the master CPU.

Number of communications points:

1 point

Communications type: RS232C, RS422A, RS485

Communications speed: 2400/4800/9600/19200/38400 bps

Protocol: MODBUS (RTU), MODBUS (ASCII), PRIVATE

● 2-output type

2 kinds of output with direct and reverse actions are outputted and simultaneous control of heating/cooling is enabled.

Control cycle: Approx. 0.1 seconds
 Output type: ON-OFF pulse type, Current output type, Voltage output type, SSR drive pulse type
 Any combinations of these types are enabled.
 Control system: PID system

● External set value switching

The selection of executing No. (SV) is enabled.

Number of inputs: 4 points
 Input signal: No-voltage contact, open-collector signal
 External contact capacity: 5VDC 2mA

● Panel sealing

By mounting the controller to a panel, it has the panel sealing equivalent to [IP54 compliance].

● Terminal cover

It covers the terminals for safe. The cover is transparent.

■ DETAILED SPECIFICATIONS OF ACCURACY RATINGS

Input type		Accuracy rating	Exceptional specifications
Thermocouple	B	±0.1% ± 1digit	Less than 400°C: Not specified / 400°C to less than 800°C: ±0.2% ± 1 digit
	R, S		0°C to less than 400°C: ±0.2% ± 1 digit
	N		
	K		-200°C to less than 0°C: ±0.2% ± 1digit or the value equivalent to ±60 μV, whichever is greater
	E		-270°C to less than 0°C: ±0.2% ± 1digit or the value equivalent to ±80 μV, whichever is greater
	J		-200°C to less than 0°C: ±0.2% ± 1digit or the value equivalent to ±80 μV, whichever is greater
	T		-270°C to less than 0°C: ±0.2% ± 1digit or the value equivalent to ±40 μV, whichever is greater
	U		-200°C to less than 0°C: ±0.2% ± 1digit or the value equivalent to ±40 μV, whichever is greater
	L		-200°C to less than 0°C: ±0.2% ± 1digit
	WRe5-WRe26		
	W-WRe26	0°C to less than 400°C ±0.3% ± 1 digit	
	NiMo-Ni		
	Platine I II		
	CR-AuFe	±0.2% ± 1digit	0K to less than 200K: ±0.5% ± 1 digit / 20K to less than 50K: ±0.3% ± 1 digit
PR5-20	0°C to less than 100°C: Not specified / 100°C to less than 200°C: ±0.5% ± 1 digit		
PtRh40-PtRh20	0°C to less than 400°C: ±1.5% ± 1 digit / 400°C to less than 800°C: ±0.8% ± 1 digit		
DC voltage / DC current		±0.1% ± 1digit	
Resistance thermometer	Pt100	±0.1% ± 1digit	For the measuring range of [-100°C to 100°C] only: ±0.15% ± 1digit
	Old Pt100		
	JPt100		
	JPt50		
	Pt-Co	±0.15% ± 1digit	4K to less than 20K : ±0.5% ± 1digit / 20K to less than 50K : ±0.3% ± 1digit

* The above ratings are the measurement range conversion accuracies under the reference operating conditions.

For thermocouple inputs, the reference junction compensation accuracy is added.

* K, E, J, T, R, S, B, N : IEC584 (1977 - 1982), JIS C 1602 - 1995, JIS C 1605 - 1995
 WRe5-WRe26, W-WRe26, NiMo-Ni, Platine I II, CR-AuFe, PtRh40-PtRh20 : ASTM Vol.14.03
 U, L : DIN43710 - 1985

Pt100 : IEC751 (1995), JIS C 1604 -1997
 Old dPt100 : IEC751 (1983), JIS C 1604 - 1989, JIS C 1606 - 1989
 JPt100 : JIS C 1604-1981, JIS C 1606 - 1986
 JPt50 : JIS C 1604 -1981

■ TERMINAL ARRANGEMENT

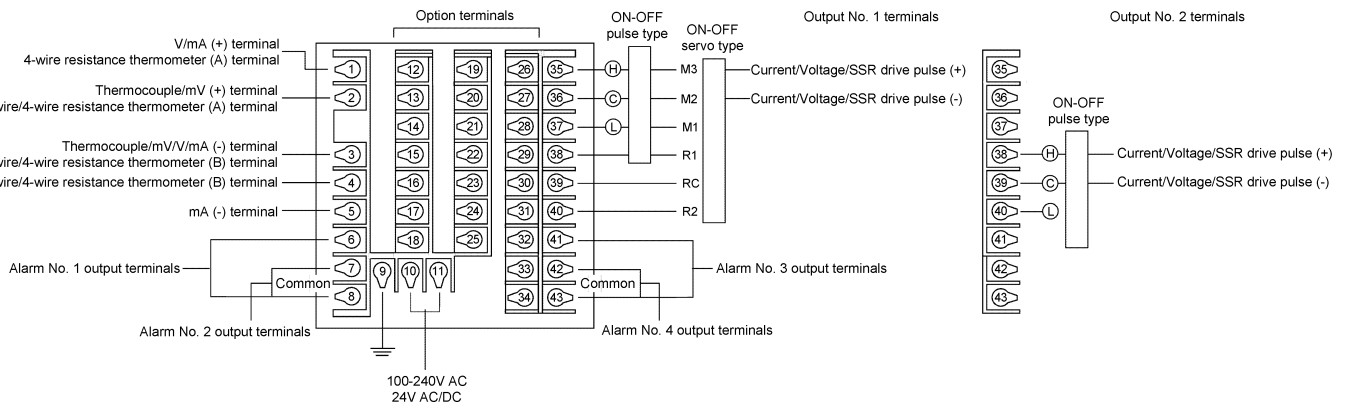

● Option terminals

Communications interface (1st zone)

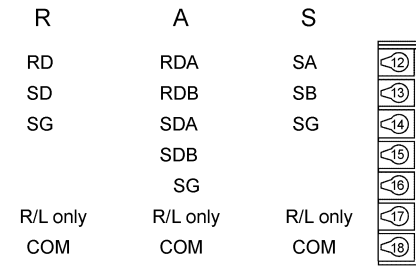

R : RS232C A : RS422A S : RS485

Transmission signal output (2nd zone)

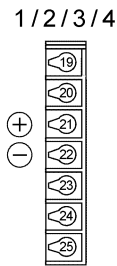

Remote signal input (3rd zone)

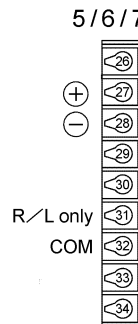

External set value switching

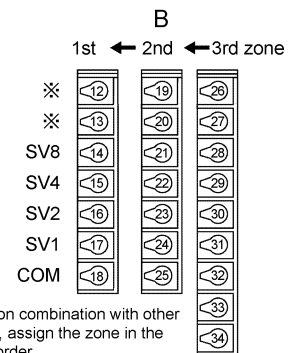

Based on combination with other options, assign the zone in the above order.

※Preset manual or remote A/M switching terminals (option)

● ABOUT CRIMP STYLE TERMINALS

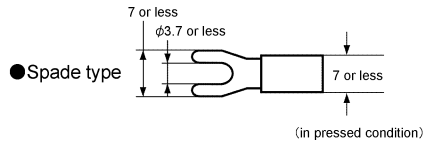
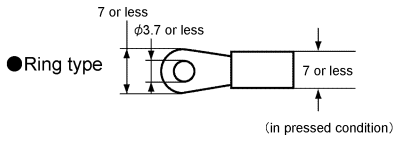

*Use terminal with insulation

■ EXTENAL DIMENSIONES

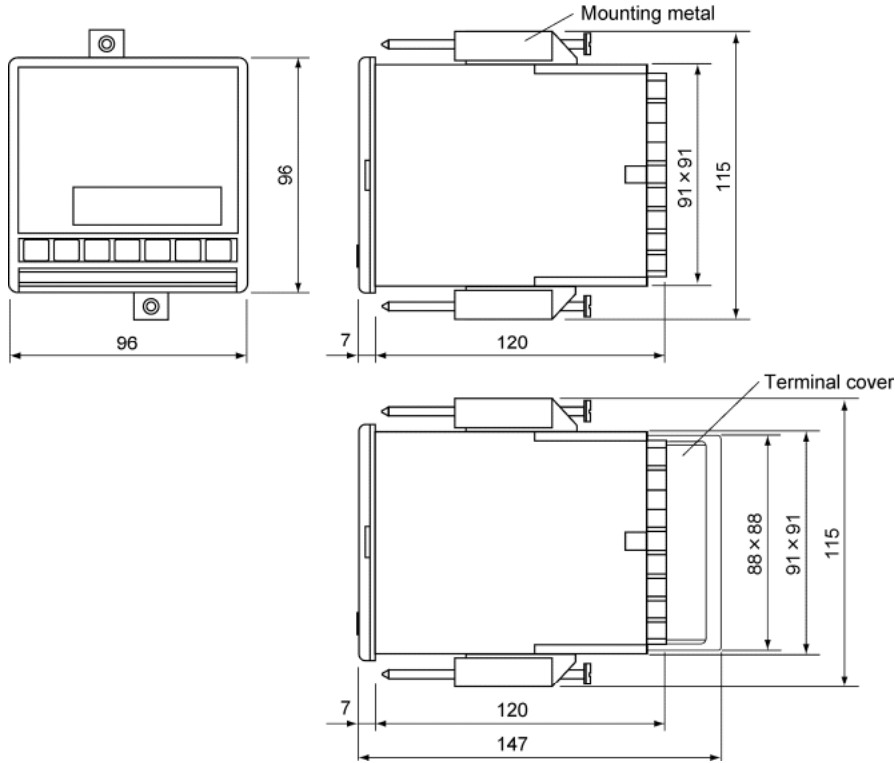

● PANEL CUTOUT

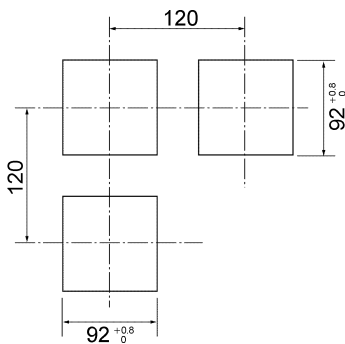

● Closed mounting panel dimensions

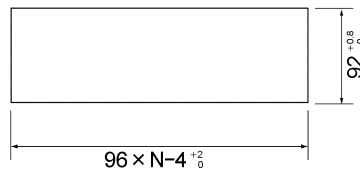

N: Number of mounted instruments

Unit: mm

Specifications subject to change without notice. Printed in Japan (I) 2008. 2. Recycled Paper

CHINO CORPORATION

32-8 KUMANO-CHO, ITABASHI-KU, TOKYO 173-8632
PHONE: +81-3-3956-2171
FAX: +81-3-3956-0915
E-mail: inter@chino.co.jp
Website: <http://www.chino.co.jp>



mawi-therm
Temperatur-Prozess-technik GmbH
Hofstraße 23 • D-40789 Monheim
phone +49 2173 51094
fax +49 2173 58623
e-mail info@mawitherm.com